

1550 nm Wide Band 85nm Superluminescent LED

RZSLD-1550-10-BP-00-14-HB

◆ Features:

- a. Typical Ex-fiber output power of 10mW
- b. Typical 3dB bandwidth of 85nm
- c. Spectrum covers 1510-1590nm bandwidth -25dBm/0.1nm resolution
- d. Spectral modulation of <1dB
- e. 14-pin BTF package
- f. Single-mode/PM fiber pigtail >1M

◆ Applications

- a. Fiber Optic Gyroscope
- b. Optical Test Instrument
- c. Fiber Optic Sensors
- d. Fiber Optic Communications
- e. Optical Coherence Tomography
- f. Biomedical Imaging Device
- g. Clinical Healing Equipment

◆ Absolute Maximum Ratings

Parameter	Symbol	Condition	Min	Max	Unit
Reverse voltage	VR	-	-	2	V
Forward current	IF	-	-	650	mA
Forward voltage	VF	lop	-	3.0	V
Operating Case Temperature	Tc	lop	-20	60	°C
Thermoelectric cooler voltage	VTEC	-	-	3.60	V
Thermoelectric cooler current	ITEC	-	-	2.6	A
Storage temperature	Tstg	Unbiased	-40	85	°C
Storage humidity	-	-	5	85	%RH
Electro static discharge (ESD)	VESD		-	500	V
Lead soldering temperature	Stemp	(max 60s)	-	260	°C
Lead soldering time	Stime	-	-	10	sec

◆ Specification (TSLED = 25 C)

Parameter	Symbol	Condition	Min	Typ	Max	Unit
Operating current	lop	-	-	-	600	mA
Forward voltage	VF	lop	-	-	2.5	V
Optical Output Power	Po	lop	8	10	-	mW
Central wavelength	λ	lop	1520	1550	1570	nm
Bandwidth	B _{FWHM}	lop	85	-	-	nm
Spectrum modulation	R	lop	-	-	1	dB

Thermistor resistance	Rtherm	T = 25 °C	9.5	10	10.5	kΩ
Polarization Extinction Ratio(Optional PMF)	PER	lop	15	-	-	dB
Thermoelectric cooler voltage	VTEC	lop	-	-	2.8	V
Thermoelectric cooler current	ITEC	lop	-	-	1.4	A

◆ **Dimensions and Pin Description**

Dimensions are in millimeters. All dimensions are ±0.1mm unless otherwise specified.

Type: 00

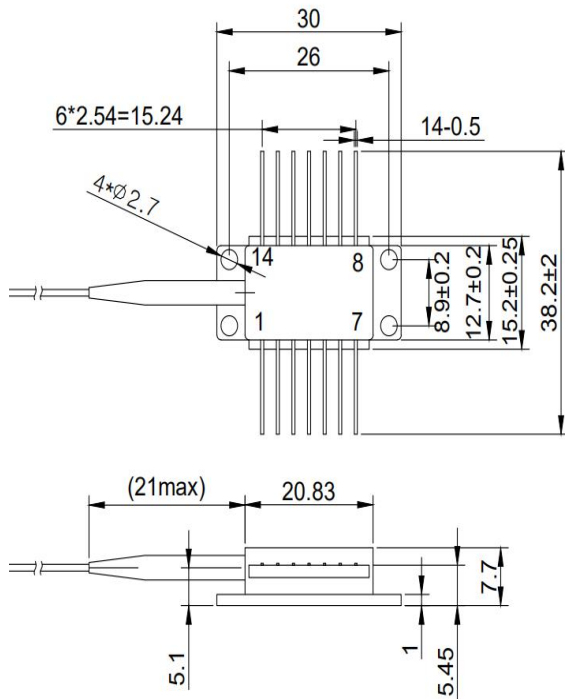

Pin	Description
1	TE Cooler (+)
2	Thermistor
3	N/C
4	N/C
5	Thermistor
6	N/C
7	N/C
8	N/C
9	N/C
10	SLED(+)
11	SLED(-)
12	N/C
13	GND
14	TE Cooler (-)

◆ **Order information**

RZSLD-1550-10-BP-00-14-HB

RZLD	wavelength	Output Power	Encapsulation & Fiber selection	Connector	PIN	Customized
RZSLD=SLE	...nm	...mW	BS=BTF SM Fiber	00=NO	14	HB=Bandwidth > 85nm
D	1550	5	BP=BTF PM Fiber	FA=FC/APC		
...	...	10	...	FU=FC/UPC		
				SA=SC/APC		
				...		

Note:The laser module are ESD-sensitive devices. Please insurw that proper ESD handling procedures are followed.